

INEXPENSIVE PERSONAL SOLAR WATER PASTEURIZER

Frank Husson Solar Solutions 10080 Willow Creek Road San Diego, CA 92131 fhusson@solarcleanwatersolution.com	Dale Andreatta S.E.A., Inc. 7349 Worthington-Galena Rd. Columbus, OH 43085 dandreatta@seaohio.com
---	---

ABSTRACT

Diseases caused by unclean drinking water are one of the greatest health problems facing the developing world. One method of purifying biologically contaminated water is pasteurization, the heating of the water to a temperature sufficient to kill all germs, viruses, and parasites. A number of small inexpensive devices for pasteurizing water have been developed, and these devices are described in this paper. They work well under good climatic conditions. One of these devices has been extensively tested and is ready for mass production. Two other devices are in a more experimental stage of development.

1. INTRODUCTION

Over one billion people live without access to potable water and over 6,000 children die every day from drinking contaminated water. Most of these people live in tropical or sub-tropical rural parts of developing countries. Because of low population density in these remote locations, it is very difficult and expensive to justify traditional infrastructure such as drilling wells to obtain potable water. On most days, sufficient sunlight exists in these countries to use an inexpensive solar water pasteurizer based on the 140 year-old discovery by Louis Pasteur to eliminate all known harmful water-borne pathogens from a fresh water source. Many developing countries also lack sustainable development and employment opportunities.

2. THE AQUAPAK

The AquaPak solar water pasteurizer has been specifically designed so that it can be mass-produced in "copy exactly" manufacturing facilities in developing countries. These enterprises will not only address the water crisis in the area, but will also create job opportunities and boost the local economy. Furthermore, the AquaPak can easily be manufactured in developing countries for less than \$2.00 per unit, making the device the least expensive way known to heat and purify water. In the past, no one has been able to produce a solar pasteurizer cheaply enough to be widely deployed in poor areas. At less than \$2.00 per unit, the AquaPak produces water at under \$0.20 per cubic meter, compared to batch chlorination at \$0.20 per cubic meter or photovoltaic-UV treatment at over \$0.60 per cubic meter (Ref. 1).



Fig. 1: The AquaPak.

The AquaPak is a ready-to-use product constructed of FDA approved UV inhibited polyethylene which is quite durable. The current size is about 14 inches square (0.35 meters). The AquaPak is comprised of several layers of materials that can easily, reliably, and inexpensively be assembled using a tapered thermal impulse sealing machine (Fig. 2). The sealing process bonds the edges of the plastic tightly enough for the AquaPak to pass a 10-foot (3 meter) drop test when filled with 3 liters of 80°C water.



Fig. 2: Tapered Thermal Impulse Sealing Machine.

A cross-section of the materials used in the AquaPak can be seen in Fig. 3. The bubble pack layer automatically maintains a convection gap. Sunlight enters through the bubble pack, clear plastic layer, and water and then converts into heat when it comes in contact with the black plastic layer. The bubble pack serves as a thermal insulator, which allows water to be heated to a temperature sufficient for pasteurization.

It is a common misperception that water must reach boiling temperature for pasteurization to occur. In fact, the pasteurization process can be initiated by maintaining temperatures well below boiling point for specified time periods as indicated in Ref. 2. Water can be pasteurized by maintaining it at 67° C for 15 minutes.

The AquaPak includes a glass indicator known as the WAPI (Water Pasteurization Indicator). The WAPI is filled with an orange-colored wax that melts at 67° C to indicate the start of the pasteurization process. The WAPI can be removed and inverted for reuse after the wax has resolidified. In experiments conducted by BioVir Laboratories, San Francisco, CA, on water contaminated by viral pathogens and by Environmental Engineering Laboratories, San Diego, CA, on water contaminated by bacterial pathogens, the AquaPak eradicated over 99.99% of the pathogens present.

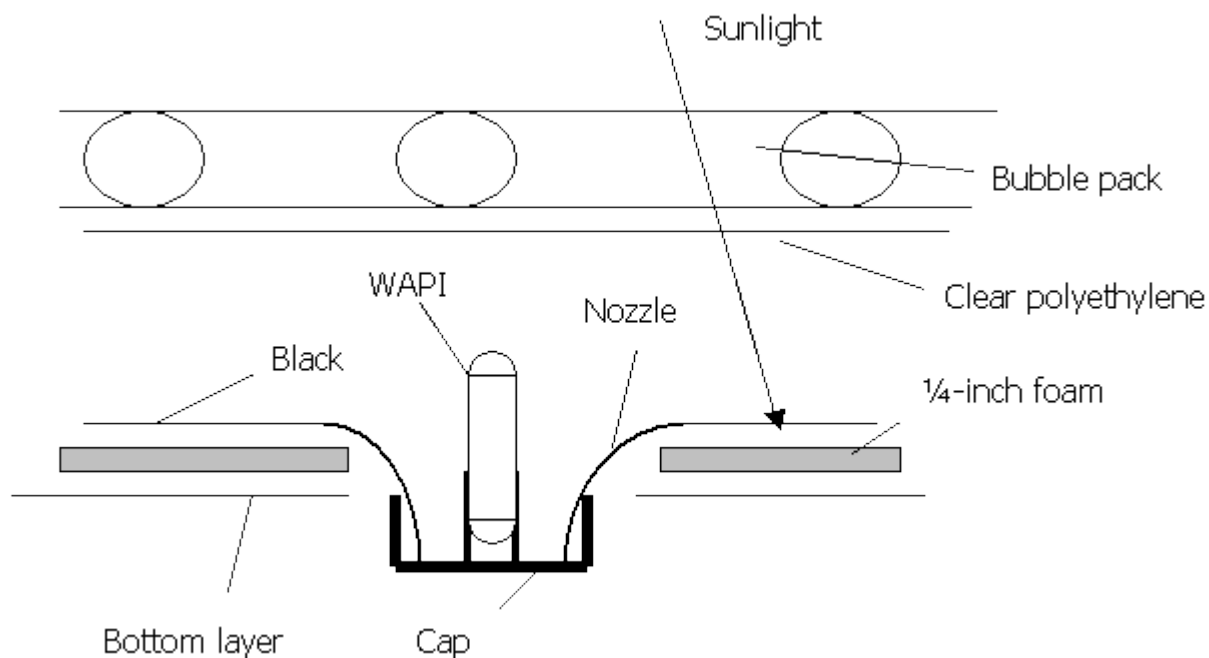

Fig. 3: Cross section of the AquaPak

(Plastic sheets are polyethylene)

Fig. 4 shows the temperature of an AquaPak with 3 liters of water on several sunny days in San Diego, latitude 33 ° N. The water temperature was ambient at sunrise. Water should heat even faster in countries close to the equator.

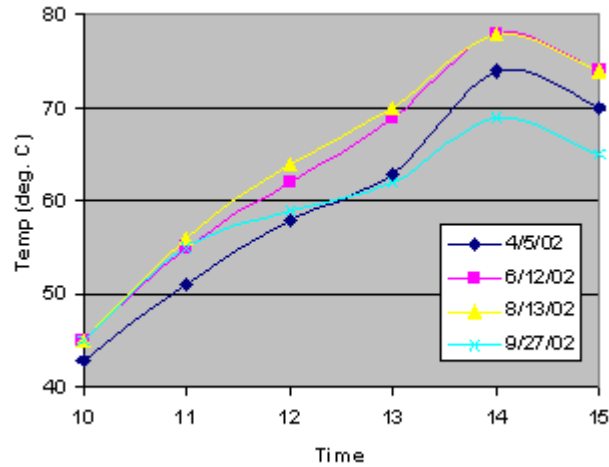

Fig. 4: Temperature vs. time for an AquaPak with 3 liters of water.

(Time is Military)

The AquaPak also includes a roughing filter, charcoal filter, and final filter. These accessories take out larger debris and help to improve the taste of the water. The AquaPak can be used on any relatively flat surface including boats, burros, carts, roofs, the ground, or even strapped to someone's back. The AquaPak can also be carried by hand, or by one or two people using a 2" or smaller pole. The bubble pack front insulation allows people to place the unit in various locations without concern of maintaining a proper air gap for insulation. The WAPI is made of glass and is hermetically sealed.

3. BUSINESS MODEL

Now that the AquaPak has been developed, patented, and tested, Solar Solutions will attempt to identify entrepreneurs and companies that will establish independently owned "copy exactly" manufacturing facilities in the developing world. Extensive hands-on training for the managers of these facilities would be provided at the San Diego manufacturing site. Solar Solutions LLC will continue to seek approval from interested non-governmental organizations (NGO's) and any other group that may buy large numbers of units at humanitarian prices from these newly formed companies. The new companies would be able to sell to the NGO's through Solar Solutions, but would also have the opportunity to sell through normal distribution channels in their home countries and to other neighboring countries.

4. OTHER SMALL PASTEURIZERS

A number of other small pasteurizers were built and tested in the summer of 2002 with the aim of seeing how small and simple a pasteurizer could be and still perform. The two most promising designs are presented here. These pasteurizers, like the AquaPak, are somewhat similar to the solar puddle that was developed in 1994 and described in Ref. 3 and in other places. The advantages of these types of pasteurizers over the AquaPak are potentially lower manufacturing costs, higher transmission of insolation leading to higher performance, and elimination of the seams, which can weaken if exposed to very high temperatures. These devices can also be used to carry water for a short distance. Unlike the AquaPak, which only needs to be filled and put in the sun, these devices require some set up time.

5. SACK PASTEURIZER

This pasteurizer cuts the manufacturing labor to near zero. In its simplest form the sack pasteurizer is nothing more than 2 pieces of plastic cut to size and shape. One sheet is circular or nearly circular, and is bunched up to form a sack to hold water as shown in Fig. 5. The top of the sack is tied shut to prevent evaporation.



Fig. 5: The sack from a sack pasteurizer filled with water and tied shut.

The fill and drain spout (nozzle) is optional, and could be used to hold the pasteurization indicator, or the indicator could be inserted from the top. Experience with the AquaPak shows that this spout is not an expensive addition. The sack is laid on a dark insulative surface and flattened out as much as possible. Black foam rubber as thin as ¼ inch (6 mm) has been used as the bottom insulator, and also serves as the absorber. Two inches (50 mm) of grass clippings have also been used and work nearly as well as the foam rubber. A single cover layer of clear plastic is used to form an insulative air gap above the water sack. This cover layer would be laid over the top of the sack and held down around the edges with whatever materials are available such as stones or dirt.

A table of sack pasteurizer performance is given below. This pasteurizer was made of a circular sheet of plastic for the sack, about 42 inches (1.1 m) in diameter. The cover sheet was about 0.7 m square (28 inches). All days had strong sun, ambient temperatures typically around 30 ° C, and all tests were conducted in Ohio, 40 ° N latitude.

TABLE 1: SACK PASTEURIZER PERFORMANCE-SUMMER 2002

Date	Max. Temp. (° C)	Bottom layer	Water (liters)
8/13	70	Black plastic on bubble wrap	3
8/20	65	6 mm black foam	3
8/21	74	black plastic on 6 mm foam	3
8/30	67	black plastic on 50 mm grass	3
9/4	71	50 mm grass (no plastic)	3
9/5	65	50 mm grass (no plastic)	4

On most days, the sack pasteurizer achieved peak temperatures a few degrees higher than an AquaPak with an equal amount of water. As with most small pasteurizers of the puddle type, light wind and condensation in the upper layer seemed to make little difference. Also as with most puddle-type pasteurizers, they did not perform nearly as well on partly cloudy days.

Larger sack pasteurizers can be made. The largest to date started with an oval sheet, 1.2 m by 1.5 m (4 feet by 5 feet) and held 5.8 liters of water during its test. A temperature of 62 ° C was reached on a less-than-ideal day in the late summer. (On the same day an AquaPak with 4 liters reached a peak temperature of 54 ° C.) The cost of this size of sack pasteurizer would be about \$1 to \$1.50 depending on whether commercial insulation was used for the base or something less expensive. This is for the same type of polyethylene plastic which is used in the AquaPak and which was described previously.

6. TUBE PASTEURIZER

The advantages of the tube pasteurizer are that a minimum of material is used and transmissivity is maximized. The water container itself is a tube of thin clear plastic, which is sometimes available in rolls, or can be made from a sheet of plastic using heat seams or even sewn. When partly filled with water the tube flattens out. A cross-section of the tube pasteurizer is shown in Fig. 6, and the pasteurizer can be as long as the length of flat ground will allow. The base of this type of pasteurizer can be the same as the sack pasteurizer, it can be as simple as a layer of grass clippings or other organic material, or can be a thin layer of dark foam rubber or some other commercial insulation. The ends of the tube would be rolled up and elevated to prevent leakage, then clipped, sealed, or sewn shut to prevent evaporation. Like the sack pasteurizer, a spout can be added at small additional expense. The tube pasteurizer can be rolled up for shipment.

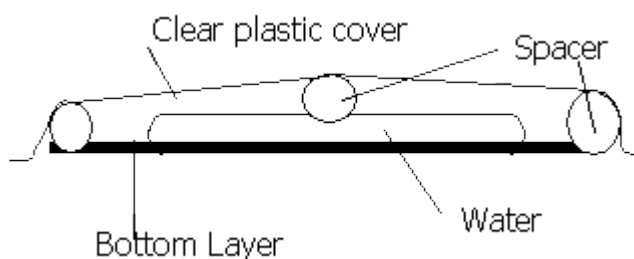

Fig. 6: Cross section of tube pasteurizer.

Limited tests were performed at the end of the summer (early to mid-September) in Ohio. A tube was used that was about 0.75 meters (30 inches) long by about 0.37 m (15 inches) wide when flattened out. Over 11 liters of water were used and temperatures considerably higher than the AquaPak (with 4 liters) were achieved. Pasteurization temperatures were achieved on days with good sun. On some days a small reflector was used on the north side of the tube (with the tube axis running east-west), which improved the performance even more, though the reflector is not necessary to achieve pasteurization temperatures on clear days.

The cost of this size of tube pasteurizer (without reflector) would be around \$0.75 to \$1.50 depending on whether a commercial bottom layer was used or some type of non-commercial material, and on whether the plastic was available in a rolled tube or had to be handmade. This size of tube pasteurizer can be carried for a short distance with the water inside.

7. CONCLUSION

Small water pasteurizers with low initial cost can be built in a number of ways. Three methods are presented here, all of which work well on sunny days. These methods have various advantages and disadvantages relative to each other, but all have low initial cost and can provide drinking water for an individual or small group.

8. ACKNOWLEDGEMENTS

The authors acknowledge Ian Robberechts for aiding in the organization of this paper, Luis Briseno of Solar Solutions for conducting many of the experiments reported here, and S.E.A., Inc. for providing support for some of this research.

9. REFERENCES

- (1) Burch, Jay, Solar Buildings Program Weekly Highlight, April 9, 2002, National Renewable Energy Lab
- (2) Feachem, R.E., Brakley, D.J., and Mara, D.D., Sanitation and Disease: Health Aspects of Excreta and Wastewater Management, Fig. 5-9, p. 79, John Wiley and Sons, 1983
- (3) Andreatta, Dale, The Solar Puddle-A Low Cost Water Pasteurizer, Proceedings of the 2001 American Solar Energy Society Conference, 2001

For more information contact:

Frank Husson
Solar Solutions LLC
USA 858.695-3806

Email: fhusson@solarcleanwatersolution.com